

Variable displacement vane pumps (with hydraulic pressure compensator with horse power limiter device)

PSPK-Type



Key Features:

- Rotation:** Right (viewed from shaft end)
- Mounting flanges:** 4-hole flange (UNI ISO 3019/2)
- Connections:** GAS BSP (UNI ISO 228/1) and SAE
- Mechanical displacement limiter "Q" on request**
- All pumps are already set up as standard to be coupled to each other and with other types of pump**
- Wide choice of pressure and flow regulation controls**

Series/Name	Rated Displacement (cm ³ /r [in ³ /r])	Maximum Flow Capacity at 1450 rpm (L/min) [US gpm]	Maximum Pressure (bar) [psi]
02-PSPK-1-16	16 [0.98]	23 [6.08]	160 [2321]
02-PSPK-1-20	20 [1.22]	29 [7.66]	160 [2321]
02-PSPK-1-25	25 [1.53]	36 [9.51]	160 [2321]
02-PSPK-2-31	31 [1.89]	45 [11.89]	160 [2321]
02-PSPK-2-40	40 [2.44]	58 [15.32]	160 [2321]
02-PSPK-2-50	50 [3.05]	73 [19.28]	160 [2321]
02-PSPK-3-63	63 [3.84]	91 [24.04]	150 [2176]
02-PSPK-3-80	80 [4.88]	116 [30.64]	150 [2176]
02-PSPK-3-100	100 [6.10]	145 [38.30]	150 [2176]

CONTENTS

GENERAL DESCRIPTION E-3

TECHNICAL DATA E-4

HOW TO ORDER E-5

ORDERING CODE E-6

DIMENSIONS E-7

INSTRUCTIONS FOR INSTALLATION AND USE E-8

WARNING

All Berarma pumps have been carefully checked during manufacture and subjected to stringent testing cycles before shipment. To achieve optimum performance, avoid problems and maintain the warranty, the installation instructions enclosed with each pump must be strictly observed.

NOTES

Before selection or use of any Berarma product, it is important that the purchaser analyses all aspects of its application and reviews the information in the current Berarma Technical-Sales catalogues. Due to the many different operating conditions and applications for Berarma products, the purchaser, through their own analysis and testing, is solely responsible for making the final selection of the products and assuring that all performance and safety requirements are met.

Berarma S.r.l. accepts no responsibility for any editing mistakes in this catalogue.
Berarma S.r.l. reserves the right to modify these data without prior notice.

GENERAL DESCRIPTION

BERARMA is continually looking for solutions which would allow it to offer increasingly advanced systems and components to its users.

Therefore, BERARMA has designed a HORSE POWER LIMITER device for its PSP-type variable displacement vane pumps.

This device allows the optimum usage of absorbed power.

The operating principle is based on maintaining the flow-pressure product ($q \times p$) practically constant, so that when the pressure increases, the flow decreases, according to a hyperbolic-type characteristic curve.

BERARMA pumps with HORSE POWER LIMITER device are especially suited for those systems with a work cycle consisting of two operating phases:

- a first phase characterized by a quick-approach at low pressure;
- a second phase characterized by low speed and high pressure (e.g. forming, drawing, blanking presses, etc....).

In this way, it is possible to set up a system using only one pump, where previously two pumps were required, resulting in obvious cost savings.

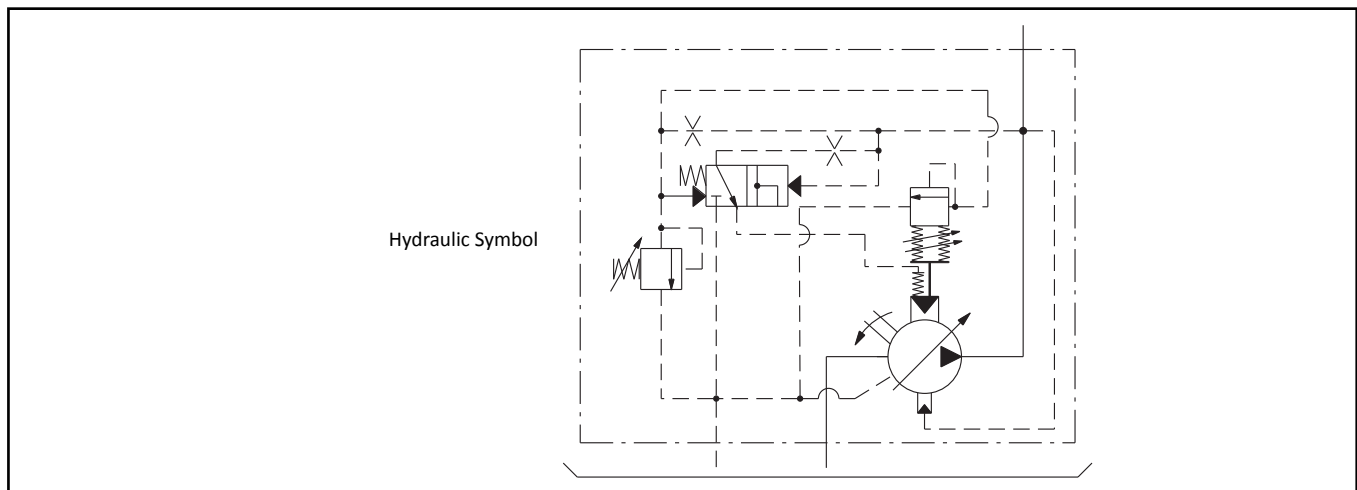

TECHNICAL DATA

Nominal size	Size 1	Size 2	Size 3
Geometric displacement according to UNI ISO 3662 (cm ³ /r) [in ³ /r]	16 - 20 - 25 [0.976;1.220;1.526]	31.5 - 40 - 50 [1.922;2.441;3.051]	63 - 80 - 100 [3.845;4.882;6.102]
Actual displacement (cm ³ /r) [in ³ /r]	17.9 - 22.1 - 26.9 [1.092;1.349;1.642]	34.5 - 42.8 - 53.1 [2.105;2.612;3.240]	69 - 86.2 - 105.5 [4.211;5.260;6.438]
Mounting flange - Port Connections	F (UNI ISO 3019/2 - GAS BSP thread)		
Maximum working pressure (bar) [psi]	160 [2321]	160 [2321]	150 [2176]
Control pressure setting (bar) [psi]	H: 30/160 [435/2321]		H:30/150 [435/2176]
Permitted maximum drain port pressure (bar) [psi]	1 [14.5]		
Inlet pressure (absolute - bar) [psi]	0.8 - 1.5 [11.6 - 21.8]		
Speed range (r/min)	800 - 1800		
Rotation direction (viewed from shaft end)	Right (clockwise) R		
Loads on drive shaft	NO RADIAL OR AXIAL LOADS ALLOWED		
Maximum torque on primary shaft (Nm) [lb-in]	197 [1744]	400 [3540]	740 [6550]
Hydraulic fluid	HM hydraulic oil according to ISO 6743/4; HLP hydraulic oil according to DIN 51524/2 organic ester HFD-U according to ISO 6743/4 (Quintolubric N822-300) for other fluids contact Berarma Technical-Sales Service		
Viscosity range (cSt, mm ² /s)	22 - 68		
Starting viscosity under full flow conditions (cSt, mm ² /s)	400 max		
Viscosity index according to ISO/DIS 2909	100 min		
Inlet fluid temperature range (°C) [°F]	-10 / +50 [14 / 122]		
Maximum acceptable fluid contamination level	20/18/15 according to ISO 4406/99, CLASS 9 according to NAS 1638		
Recommended fluid contamination level for a longer pump working life	18/16/13 according to ISO 4406/99, CLASS 7 according to NAS 1638		
Weight (approximate value for standard configuration pump - Kg) [lb]	15 [33]	35 [77]	47 [103.5]
<ul style="list-style-type: none"> • For different operating conditions, please contact Berarma Technical Service • For further PSPK pump technical data (noise level, ...) please consult the "Variable displacement vane pump type O2 PSP" Berarma catalogue 			

HOW TO ORDER

The PSPK pump can be ordered in two different ways:

- 1) starting from the power value of the motor (contact BERARMA Technical Service to find out the available power values) and from the maximum working pressure, thus obtaining a characteristic curve making it possible for the pump to optimize installed power usage;
- 2) starting from the minimum flow value to be obtained at the previously defined maximum working pressure. In this way the motor power and the characteristic curve are determined from defined operating conditions.

Starting from the motor power value and maximum working pressure value indicated in the ordering code, BERARMA performs the bench calibration of the horse power limiter device so that the actual characteristic curve of the pump approximates the theoretical hyperbolic curve.

Note: the setting of the horse power limiter device must not be changed by users.

The pump absorbed power can be calculated using the following formula:

$$P \text{ [kW]} = \frac{p \text{ [bar]} \times q \text{ [l/min]}}{600 \times \eta}$$

where:

η = pump total efficiency ($\eta \sim 0.88$, purely indicative) ($P \text{ [hp]} \sim P \text{ [kW]} / 0.75$)

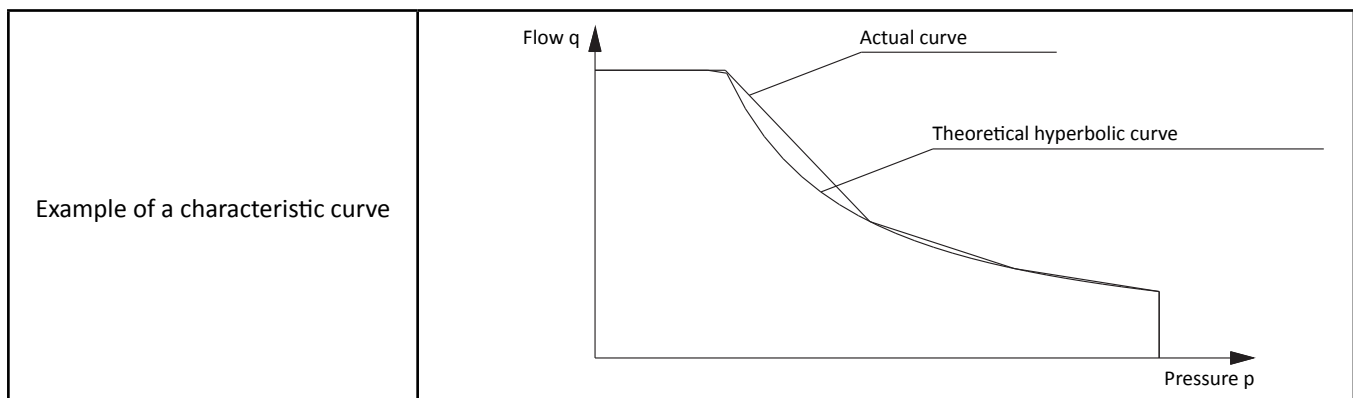

ORDERING CODE

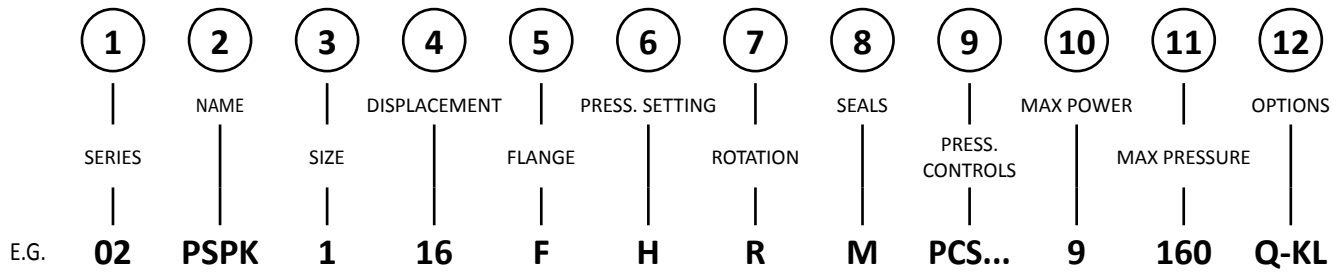

- 1** PUMP SERIES = 02
- 2** PUMP NAME = PSPK
- 3** PUMP SIZE = 1, 2, 3
- 4** DISPLACEMENT CM³/R = 16 - 20 - 25 (SIZE 1)
 31 - 40 - 50 (SIZE 2)
 63 - 80 - 100 (SIZE 3)
- 5** FLANGE AND PORT CONNECTIONS =
F (UNI ISO 3019/2 - GAS BSP thread)
- 6** CONTROL PRESSURE SETTING = H 30 ÷ 160 bar [435 ÷ 2321 psi] (SIZE 1-2)
 30 ÷ 150 bar [435 ÷ 2176 psi] (SIZE 3)
- 7** ROTATION = R (Right-hand rotation viewed from shaft end)
- 8** SEALS = M (NBR)
 E (FPM-Viton)
- 9** PRESSURE CONTROL SOLUTIONS =
PCS002 Remote pressure control
PCS003 Two pressure stages
PCS005 Proportional press. control
- 10** MAX POWER = ... kW
- 11** MAX PRESSURE = ... bar
- 12** OPTIONS = KL (Key lock compensator)
 Q (Flow regulation screw)

Note:

- 1) In the PCS002, PCS003 and PCS005 configurations, the PSPK pump is supplied with the CETOP 03 mounting surface. For further information about pressure control solutions, please consult the "Variable displacement vane pump type 02 PSP" BERARMA catalogue.
- 2) BERARMA PSPK pumps are already set up as standard to be coupled to each other. For further information, please contact BERARMA Technical Service.
- 3) For further information about point 12 of the ordering code, please consult the "Variable displacement vane pump type 02 PSP" BERARMA catalogue.

DIMENSIONS

02 PSPK 1 16-20-25

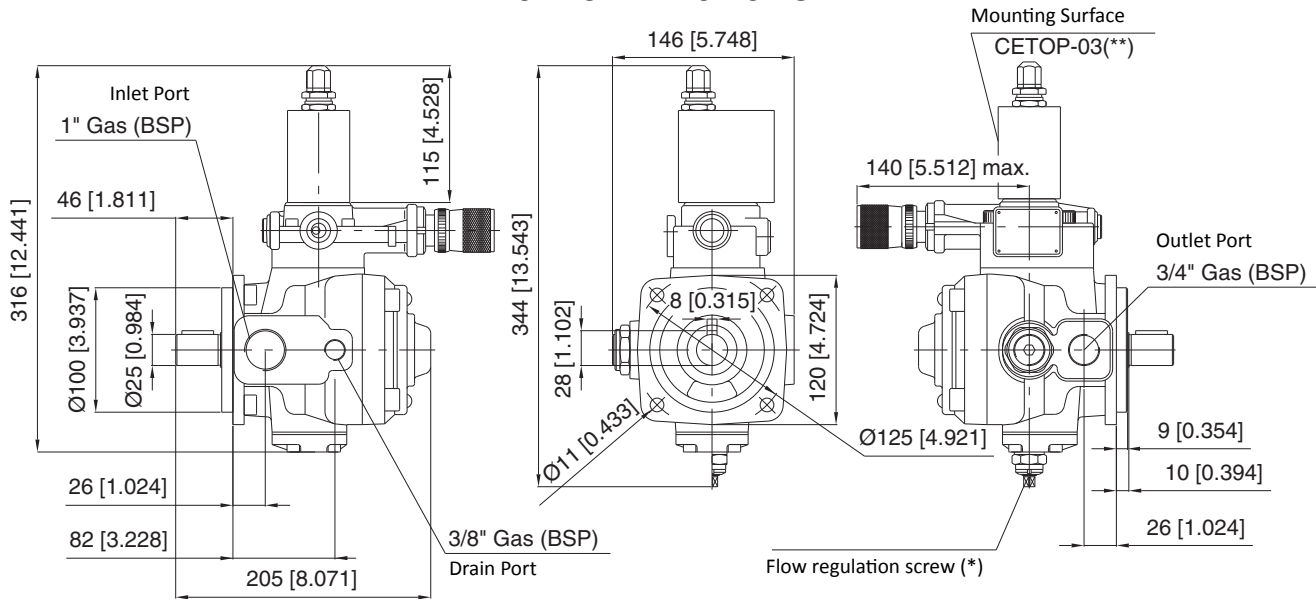

*- Option

** - PCS002, PCS003, PCS005 Pressure Control Solutions

02 PSPK 2 31-40-50 / 02 PSPK 3 63-80-100

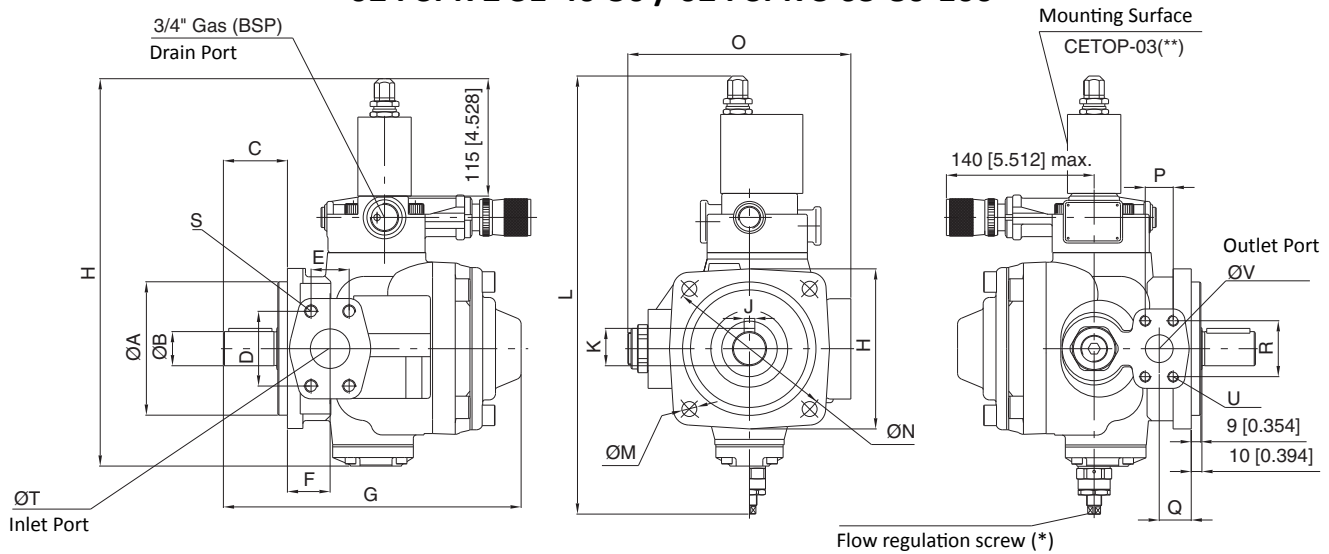

*- Option

** - PCS002, PCS003, PCS005 Pressure Control Solutions

Inlet and outlet port connections: SAE 3000

	ØA	ØB	C	D	E	F	G	H	J	K	L	ØM	ØN	O	P	Q	R	S	ØT	U	ØV
SIZE 2	125 [4.921]	32 [1.260]	60 [2.362]	70 [2.756]	35.7 [1.406]	40 [1.575]	279 [10.984]	371 [14.606]	10 [0.394]	35 [1.378]	416 [16.378]	14 [0.551]	160 [6.299]	209 [8.228]	26.2 [1.032]	30 [1.181]	52.4 [2.063]	SAE1"1/2 M12x45	38 [1.496]	SAE1" M10x35	25 [0.984]
SIZE 3	160 [6.299]	40 [1.575]	68 [2.677]	77.8 [3.063]	43 [1.693]	46 [1.811]	313 [12.323]	391 [15.394]	12 [0.472]	43 [1.693]	436 [17.165]	18 [0.709]	200 [7.874]	228 [8.976]	30.2 [1.189]	35 [1.378]	58.7 [2.311]	SAE2" M12x45	51 [2.008]	SAE1"1/4 M10x40	32 [1.260]

Note:

- For further information about pumps dimensions, please consult the "Variable displacement vane pump type 02 PSP" BERARMA catalogue
- Dimensions inside [] are in inches

INSTRUCTIONS FOR INSTALLATION AND USE

- 1) Size 1 PSPK pumps can be mounted in any position.
 Sizes 2 and 3 PSPK pumps must be mounted with the shaft along a horizontal axis and with the horse power limiter device facing upward (see figure). When the pump is installed above the tank oil level, pay attention to the inlet pressure (page 4). The minimum section of the inlet pipe must be equal to the section of the thread of the pump inlet port. The inlet pipes should be as short as possible, with a small number of bends and without internal section changes.
- 2) All return and drain pipes must be positioned so that the oil cannot be sucked back directly by the pump (see figure). The oil tank must be suitably sized in order to exchange the thermal power generated by the various system components and to provide a low recycle rate.
 To ensure the maximum pump working life, the inlet oil temperature must never be above 50°C (122°F).
 In systems where the pump runs for a long time under zero flow setting conditions, the installation of a heat exchanger in the drain line is recommended. The pressure on the drain port must never exceed the specified value (page 4). The drain pipe must always be independent from the other return lines, connected directly to the tank, and extended sufficiently inside the tank so as to be below the minimum oil level to avoid generating foam. Moreover, the drain pipe must be free of restrictions and as far as possible from the inlet pipe.
- 3) Motor-pump coupling must be made with a self-aligning flexible coupling with convex teeth and a polyamide cam.
 When assembling, maximum attention must be given to the distance between the two half-couplings which must strictly fall within the values specified in the diagram below (detail "A").
 Other types of motor-pump couplings are not permitted.
 No induced RADIAL or AXIAL LOADS are allowed on the pump shaft.
- 4) During initial installation, the pump must be run under maximum flow conditions (P connected to T), with the oil flowing directly into the tank, in order to induce air bleeding. For sizes 2 and 3 there is an air bleed on the compensator.
 This phase must run for several minutes.
 Pump priming (delivery of oil to the outlet) must occur within a few seconds, otherwise the pump must be turned off and the operation repeated.
 Subsequent start-ups under zero flow setting conditions are admissible only with pressure not exceeding 30 bar (435 psi), and with the system and pump completely filled with oil.
 During the initial and subsequent starting operations, the difference between the oil temperature and the ambient temperature (body pump temperature) must not exceed 20°C (68°F).

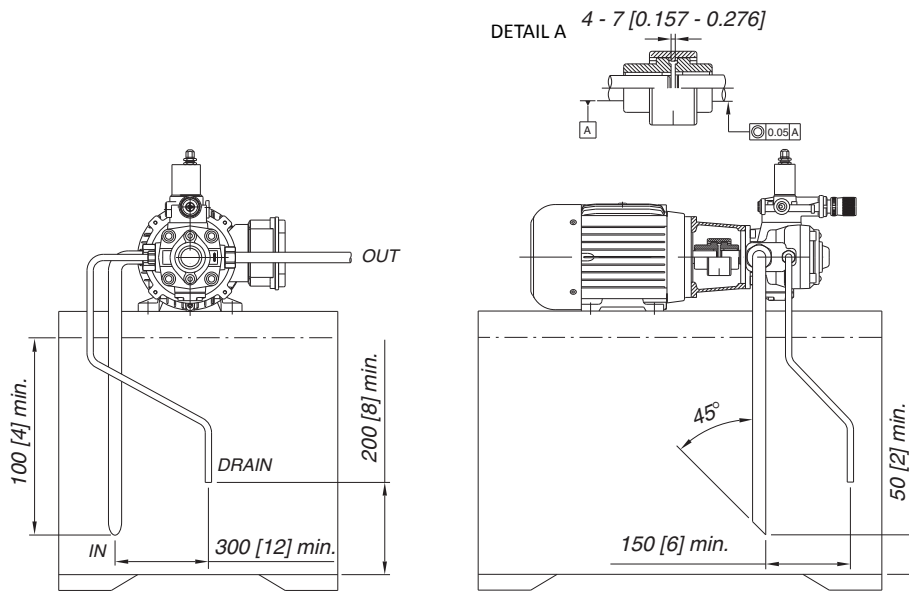

Note: dimensions inside [] are in inches